

auto electrical parts

Technical Information Sheet

Part No. 0-300-80

LED Rear lamp, 12/24 volt LED, Stop/Tail/D.I./Reflex, supplied with 300mm cable. 2 x M6 fixing bolts. ECE approved. Protected to IP67.

Additional information

Red wire	Stop
Black wire	Tail
Yellow wire	Indicator
White wire	Ground/negative



Technical Drawing (not to scale)

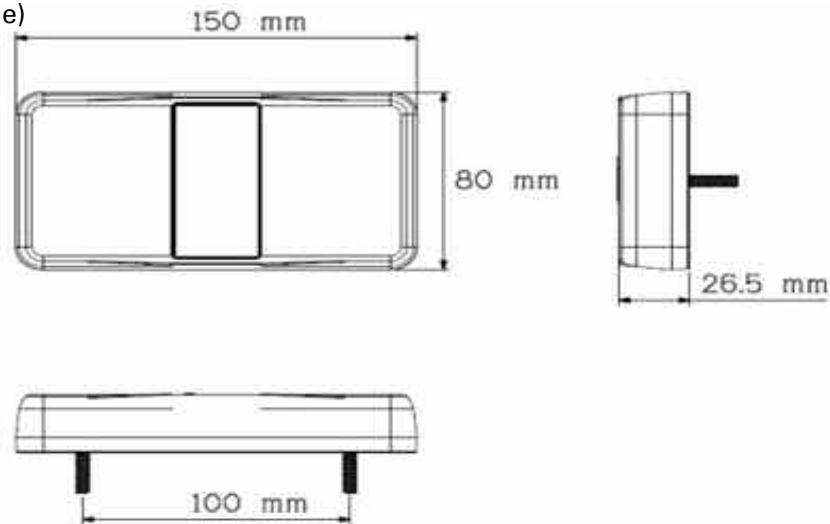

Specification

Type	LED rear lamp
Function	Stop/Tail/D.I./Reflex
Voltage	9-28volts dc
Lens	PC
Body material	PC
Lead	300mm
Dimensions	See diagram above
Protection	IP67
Compliance	ECE

The information contained in this document is correct to the best of our knowledge at the time of printing. However, specifications may change at any time without notice.